











# BRC

## SOLAR

### Product Catalog

## Power Optimizer

-  *The vision of BRC Solar*
-  *Application cases*
-  *Functionality*
-  *Power Optimizer M600-E and M700-E*
-  *Power Optimizer M605-M and BRConnect 2.0*
-  *Power Manager App*
-  *BRClamp*
-  *BRC-Advantages*
-  *Planning tools*

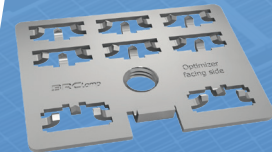
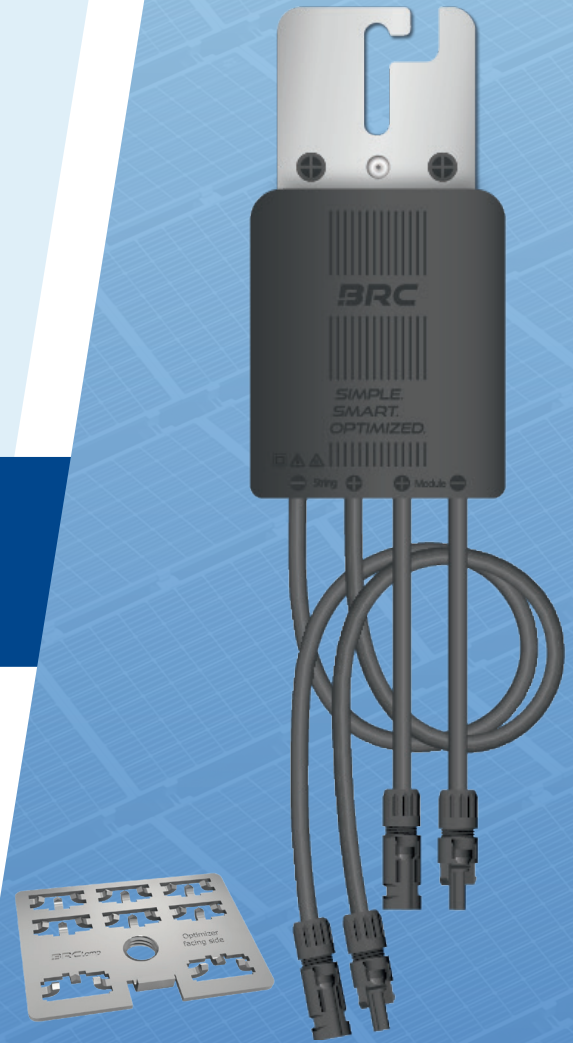

**English**

**SIMPLE.  
SMART.  
OPTIMIZED.**





**„We are not only engineers, we are pioneers for a sustainable future.“**

Quote Managing Director Pascal Ruisinger

*With innovative optimizers, we make photovoltaics more efficient and accessible for every roof - without compromising on quality and fairness. For us, it's about more than just technology: it's about taking responsibility and shaping an energy-independent future together. Our company was born from this passion. From the beginning, we have pursued the goal of offering a flexible and cost-effective technology to make photovoltaics usable on even more rooftops.*

## **Our vision**

At BRC Solar, we are united by one thing above all: our enthusiasm for photovoltaics and a pronounced cost-benefit mentality. Our vision is to develop innovative products which can be equipped with photovoltaics efficiently. Our journey began as three students full of enthusiasm for photovoltaics. In the beginning, we soldered the first prototypes together ourselves in the lab. Our company was born from this passion. Our goal was and is to create an important building block for photovoltaic technology that is flexible and cost-effective for installers. The first step towards achieving this goal was the M500 power optimizer. The focus here was on maximum efficiency, maximum independence from other components and maximum simplicity. Based on this product, we are always working closely with changing customer needs and adding new functions to our product portfolio. In doing so, we always focus on our three main values within the company.

## **Simple**

**Simple & user-friendly:** Thanks to the simple plug & play installation of our product, you save valuable time and avoid complications.

**Customer satisfaction:** Your satisfaction is our greatest concern. We strive not only to meet your expectations, but to exceed them.

## **Smart**

**Innovation:** By utilising the latest technologies and creative thinking, we develop products that are always one step ahead.

**Teamwork:** Together we achieve more. Cooperation and mutual respect within the team are the basis for our success.

## **Optimized**

**Efficiency:** We continuously optimize all our processes in order to achieve the best results with the fewest possible resources.

**Excellence:** We always strive for the highest quality and do everything we can to offer you only the best.

# Application cases

Shading

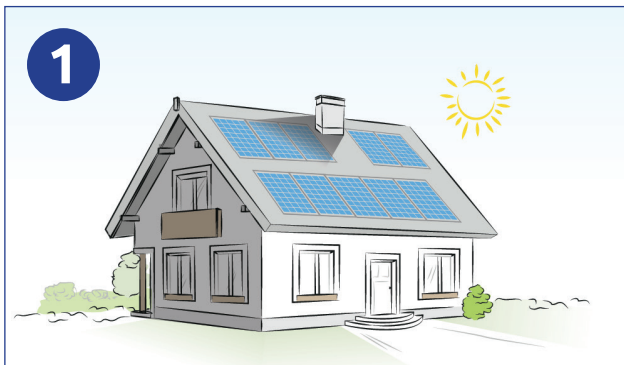

Different inclination

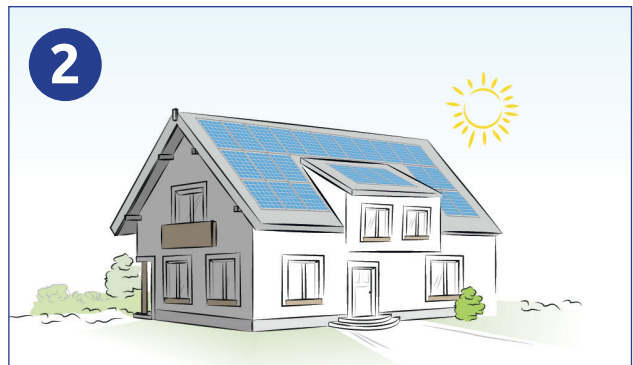

Different orientations

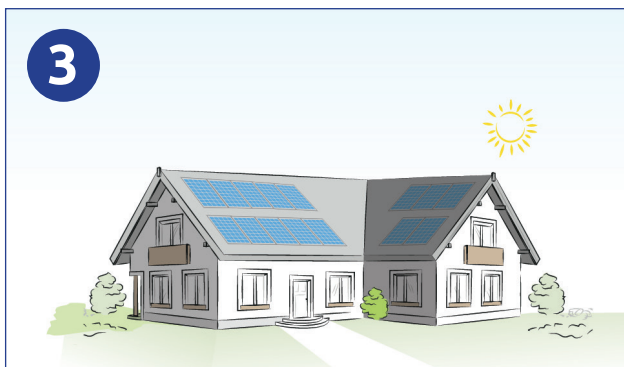

Different module types

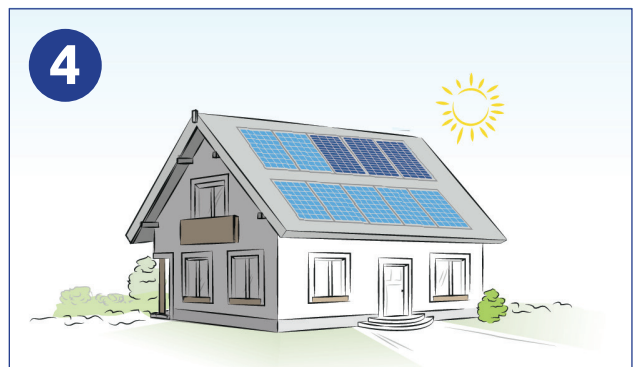

## **Description of the problem:**

Due to the series connection of the PV modules, the current in the entire string is always the same. Since the current of a module depends on the amount of sunlight it receives, the module with the least sunlight reduces the current and thus the yield of the entire string. This problem occurs mainly in cases of local shading (Fig. 1), different inclinations (Fig. 2), and different orientations (Fig. 3). The BRC optimizer is attached to these affected modules and raises the current at the module output to the level of the other modules. This prevents any reduction in performance. Replacing defective modules or expanding an existing system may require combining different module types (Fig. 4) in one string. Since these module types may also have different MPP currents, modules with lower MPP currents may slow down the other modules. This is avoided by attaching BRC optimizers to the modules with the lower current.

## **Special case for C&I systems**

Isolated shading can also occur in C&I systems. It is important to note that optimizers reduce the voltage of the module in order to maintain the current. Since the voltage must be maintained in both strings in parallel strings, optimizers are not recommended in parallel strings. To resolve local shading issues, we recommend forming a separate string with problematic modules and connecting it to a separate MPP on the inverter. This allows full optimization of the additional string without any problems.

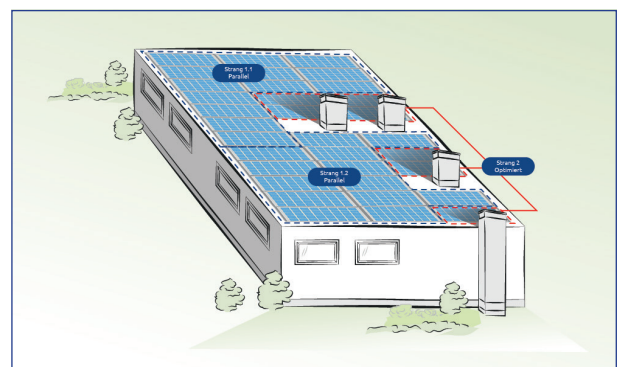

# Functionality

## The problem

Explanation for PV experts

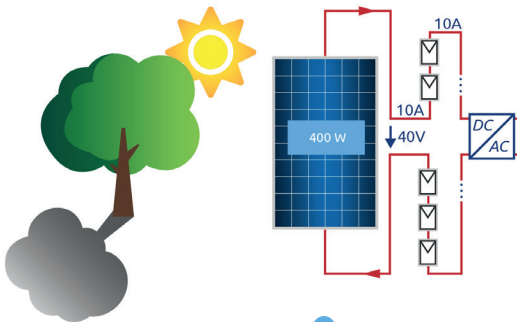

When looking at the electrical situation under optimum lighting conditions, it can be seen that one module in the example can produce 400W. There is a voltage of 40V over each module and a string current of 10A in the overall system.

However, if shade falls on the module, the output drops accordingly. In our example (see right), the shading is 50%, which is why the string current drops to 5A. As the current decreases, the output also decreases:

$$P \text{ (Power)} = U \text{ (Voltage)} * I \text{ (Current)}$$

Because all modules are connected in series in a string, the string current is now only 5A on all modules. The reason for this is the behavior of the current in a series connection:

$$I_{\text{total}} = I_1 = I_2 = \dots$$

The equation shows that the current is the same at every point in the circuit, i.e. the string current is determined by the weakest module. In this case,  $I_{\text{total}}$  is therefore 5A.

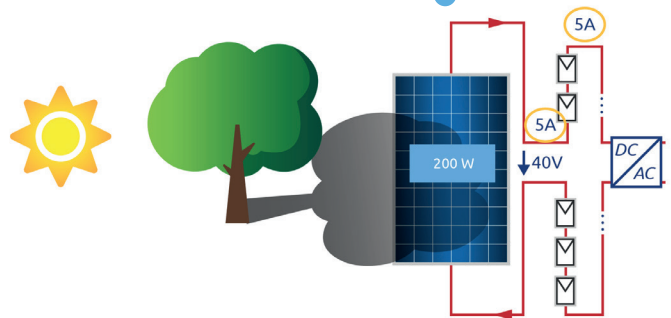

Modern inverters can avoid this problem by activating the modules' bypass diodes. If the bypass diode is activated, the shaded cell string delivers its maximum possible current and the difference to the string current flows through the bypass diode.

$$I_{\text{total}} = I_{\text{cell string}} + I_{\text{diode}}$$

In bypass mode, a current continues to flow through the shaded cell, causing it to heat up. This leads to a hot spot on the shaded cell. Depending on the duration and intensity with which it occurs, this hot spot can damage or, in the worst case, destroy the module. The bypass diodes can also be overloaded and destroyed if they are activated very frequently.

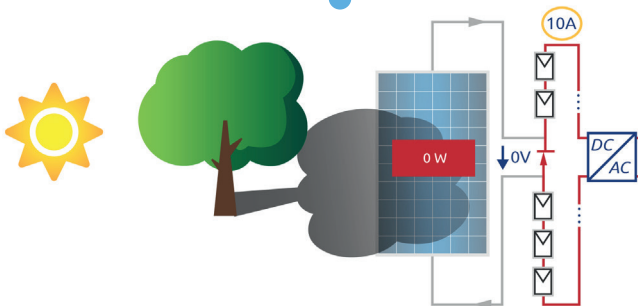

## The solution

Using the BRC Power Optimizer prevents all these problems.

The Power Optimizer is connected in parallel to the module. When shading occurs, it is automatically activated by the inverter in a similar way to the bypass diode. When activated, the Power Optimizer reduces the output voltage and increases the output current so that it corresponds to the string current. This means that the BRC Power Optimizer can continue to feed the available module power into the PV system.

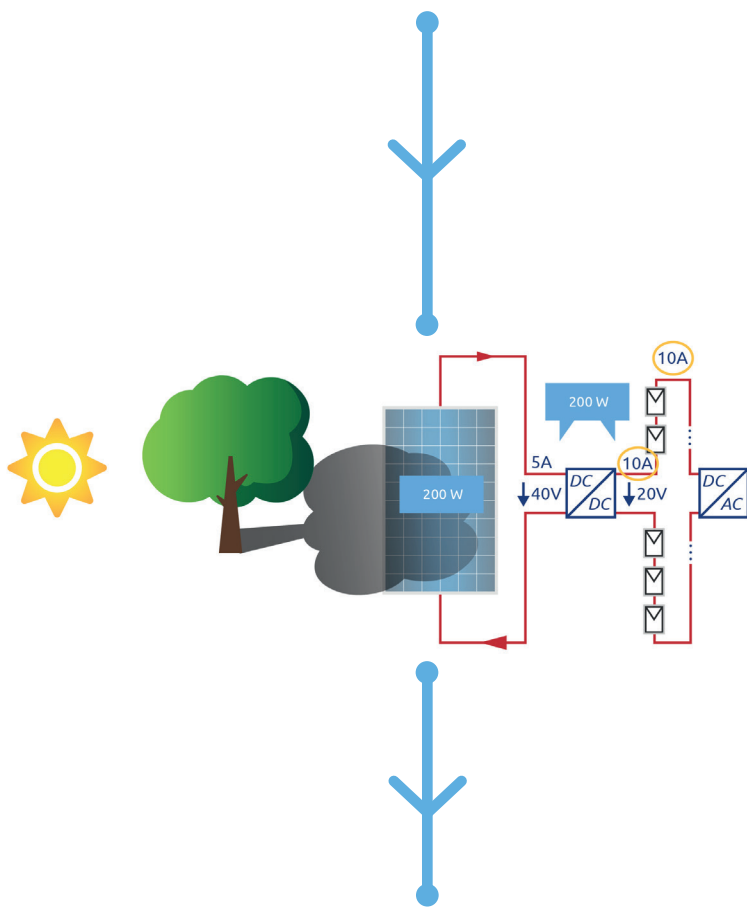

In the example, the BRC Power Optimizer converts the module voltage of 40V and the module current of 5A into an output voltage of 20V and a string current of 10A. The result is that the total string current throughout the string is now 10A again and each module can supply 10A. Although the voltage on the partially shaded module is lower, this does not affect the voltage of the other modules.

$$I_{total} = I_1 = I_2 = \dots$$

$$U_{total} = U_1 + U_2 + \dots$$

The energy yield is maximized. The problem of hot spots is also solved, as the optimizer operates the shaded module at its individual maximum operating point without the shaded cell working as an electrical load and generating power losses.

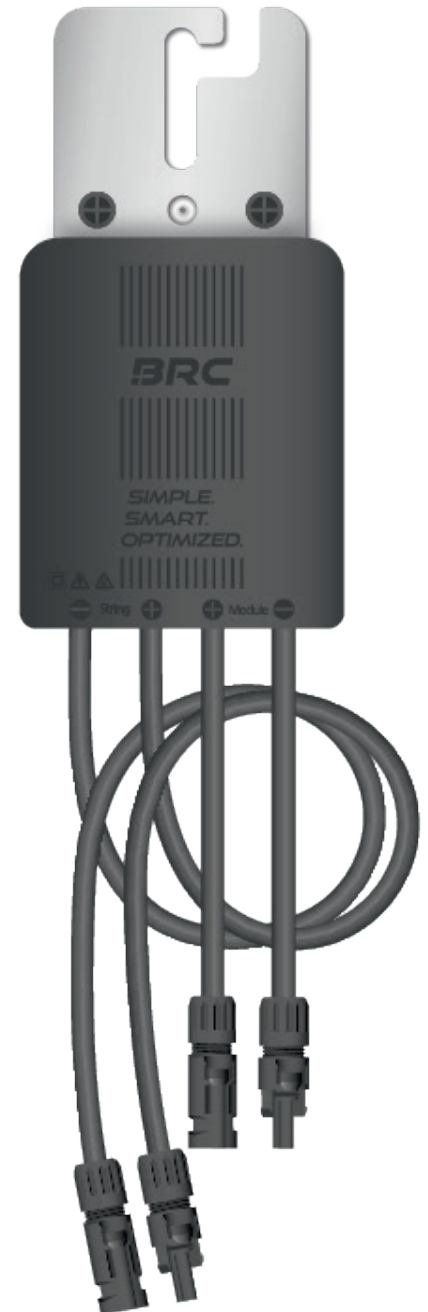

# BRC

SOLAR

GERMAN BRAND

## BRC optimizer without monitoring

Power Optimizer M600-E and M700-E



### Maximum yield

Solves the problem of shading, different orientations and different module inclinations



### Maximum quality & efficiency

Patented standby function, Ultra Fast MPP tracking with 20 times faster switching



### Simple installation

Simple plug & play system, no additional software or app required



### Inverter independence

Maximum flexibility in use, can be combined with most common inverters



M600-E



M700-E

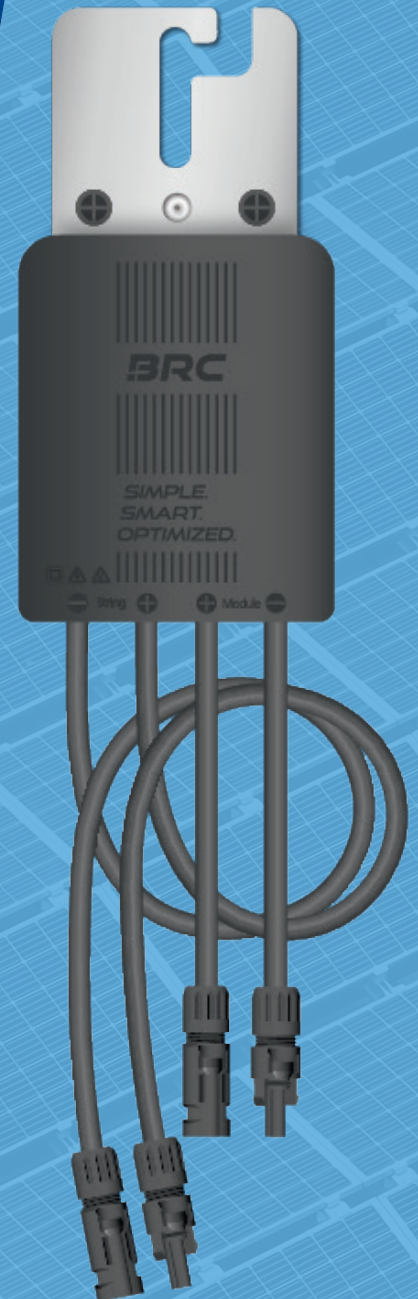

SIMPLE.  
SMART.  
OPTIMIZED.



[www.brc-solar.de](http://www.brc-solar.de)

## M600-E / M700-E COMPARED TO SYSTEM-INDEPENDENT OPTIMIZERS

### Similar product features

- Can be used independently of the inverter
- Partial configuration possible



### Time saving and simplicity

- Simple installation and connection via Plug & Play
- No app setup or initialization required
- No additional components required



### Cost savings and additional yield

- Best price-performance ratio
- Most efficient technology (patented inactivity of the power electronics when no optimization is necessary)
- 20x faster response to shading. Efficient optimization through the use of GaN transistors.



### Highest quality

- Long-life electronics (German engineering design)
- Full encapsulation inside the optimizer

## M600-E / M700-E COMPARED TO SYSTEM-DEPENDENT OPTIMIZERS



### Maximum flexibility

- Can be used independently of the inverter
- Partial configuration possible from 1 piece



### Time saving and simplicity

- Simple installation and connection via Plug & Play
- Time required for installation per optimizer approx. 2 min.
- No app setup or initialization required
- No additional components required



### Cost savings and additional yield

- Best price-performance ratio
- Most efficient technology (patented inactivity of the power electronics when no optimization is necessary)
- 20x faster response to shading. Efficient optimization through the use of GaN transistors.



### Highest quality

- Long-life electronics (German engineering design)
- Full encapsulation inside the optimizer

## PERFORMANCE COMPARISON BETWEEN POWER OPTIMIZER M600-E AND M700-E

DATA	POWER OPTIMIZER M600-E	POWER OPTIMIZER M700-E
Rated current	16 A DC	18,5 A DC
Short circuit current	20 A DC	23,2 A DC
Maximum Input Power	600 W	700 W
Output Voltage Range	0 W to 600 W	0 W to 700 W
Weight	420 g	507,5 g



Before installing the optimizers, please read the [operating instructions](#) and the [important installation specifications](#) to ensure that everything runs smoothly. Both documents can be found in the download area of our website.



#### WARRANTY

Thanks to our long-life electronics, we offer a 25-year warranty on all BRC Power Optimizer



#### LONG-LIFE ELECTRONICS

The Power Optimizer has long-life electronics thanks to our new GaN technology



#### MAXIMUM YIELD

More PV modules can be installed and more energy can be used



#### RELIABLE SUPPORT

You can reach us by e-mail and telephone for any concerns you may have

# BRC





## SOLAR

GERMAN BRAND

Now fully  
optimizable

### BRC optimizer with monitoring

Power Optimizer M605-M System  
and Gateway BRConnect 2.0

-  **Maximum yield**  
Solves the problem of shading, different orientations and different module inclinations
-  **Maximum quality & efficiency**  
Patented standby function, Ultra Fast MPP tracking with 20 times faster switching
-  **Monitoring function**  
Display of module performance via the Power Manager app
-  **Secure Communication**  
Data transmission via powerline (using DC power lines instead of wireless) and data storage exclusively on German servers



[www.brc-solar.de](http://www.brc-solar.de)



**New**



## M605-M COMPARED TO SYSTEM-INDEPENDENT OPTIMIZERS

### Similar product features

- Can be used independently of the inverter
- Use of M605-M optimizers also possible without monitoring (then partial configuration from 1 piece possible)
- Monitoring function can be retrofitted at any time with a BRConnect 2.0



### Cost savings and additional yield

- Cost savings thanks to time savings of approx. 2 hours when installing a 20KW system
- Only one additional component required for monitoring (BRConnect 2.0)
- 20x faster response to shading. Efficient optimization through the use of GaN transistors
- Most efficient technology (patented inactivity of the power electronics when no optimization is necessary)



### Maximum data security

- Data storage only on german servers



### Maximum flexibility

- Partial configuration with monitoring still possible, even with full warranty (min. 1 - max. 25 optimizers per string are required for monitoring)
- Scalable systems: Each BRConnect 2.0 can read up to two strings; up to three BRConnect 2.0 units can be used per system. This allows monitoring of up to six strings in total.



### Reliable and uncomplicated

- Simple commissioning without communication interruptions (setup and data transmission of the system via Powerline Communication/DC line, not via radio)
- Establishing communication between the M605-M optimizer and BRConnect 2.0 without plug connections (contactless data tapping via toroidal coils in the BRConnect 2.0)



### Highest quality

- Long-life electronics (German engineering design)
- Full encapsulation inside the optimizer

## M605-M COMPARED TO SYSTEM-DEPENDENT OPTIMIZERS

### Similar product features

- Simple commissioning without communication interruptions (setup and data transmission of the system via Powerline Communication/ DC line, not via radio)



### Cost savings and additional yield

- Best price - performance ratio
- Most efficient technology (patented inactivity of the power electronics when no optimization is necessary)
- 20x faster response to shading. Efficient optimization through the use of GaN transistors



### Maximum data security

- Data storage only on german servers



### Maximum flexibility

- Can be used independently of the inverter
- Partial equipment also possible with monitoring (min. 1 - max. 25 optimizers per string)
- Scalable systems: Each BRConnect 2.0 can read up to two strings; up to three BRConnect 2.0 units can be used per system. This allows monitoring of up to six strings in total.
- Use of M605-M optimizers also possible without monitoring
- Monitoring function can be retrofitted at any time with a BRConnect 2.0



### Reliable and uncomplicated

- Establishing communication between BRConnect 2.0 and M605-M optimizer without plug connections (contactless data pick-up via toroidal coils in the BRConnect 2.0)



### Highest quality

- Long-life electronics (German engineering design)
- Full encapsulation inside the optimizer



Before installing the optimizers, please read the [operating instructions](#) and the [important installation specifications](#) to ensure that everything runs smoothly. Both documents can be found in the download area of our website.



#### WARRANTY

Thanks to our long-life electronics, we offer a 25-year warranty on all Power Optimizer



#### LONG-LIFE ELECTRONICS

The Power Optimizer has long-life electronics thanks to our new GaN technology



#### MAXIMUM YIELD

More PV modules can be installed and more energy can be used



#### RELIABLE SUPPORT

You can reach us by e-mail and telephone for any concerns you may have

# Functionality M605-M and BRConnect 2.0

## Monitoring at module level

Would you like to know how much power your PV system and the individual modules are currently producing?  
 Would you like to see which BRC optimizer is currently active in your string, e.g. due to shading?

→ Then the BRC optimizer M605-M incl. BRConnect 2.0 is just right for you.

Each optimizer performs a constant measurement on its associated module and then transmits the determined data via Powerline via the string cables. Up to two strings can be routed through the BRConnect 2.0 so that it pull up the data from the respective string cables thanks to the toroidal coils. The BRConnect 2.0 processes the data and provides a precise overview of the system via the Power Manager app.

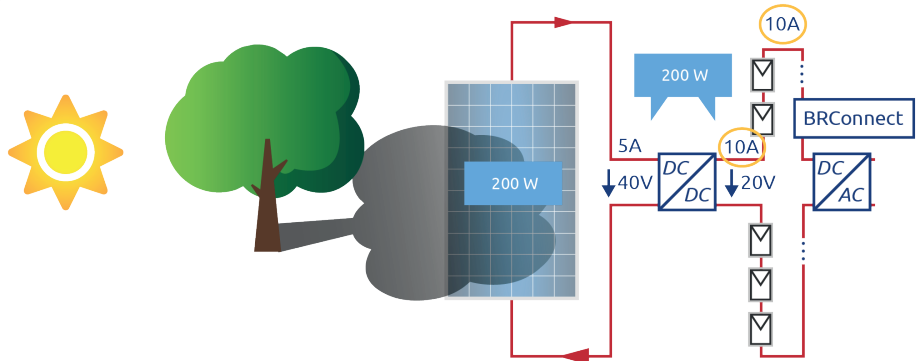

## The new Power Manager app

Easily accessible via app, available in the Appstore and Playstore

**Simple – Smart - Overview**  
 Monitoring at module level thanks to our Power Manager app. After installing the BRC Power Optimizer M605-M and the BRConnect 2.0, the respective strings can be recreated in the app using drag & drop. This makes it possible to obtain a simple overview of the individual module power outputs and the yield achieved.

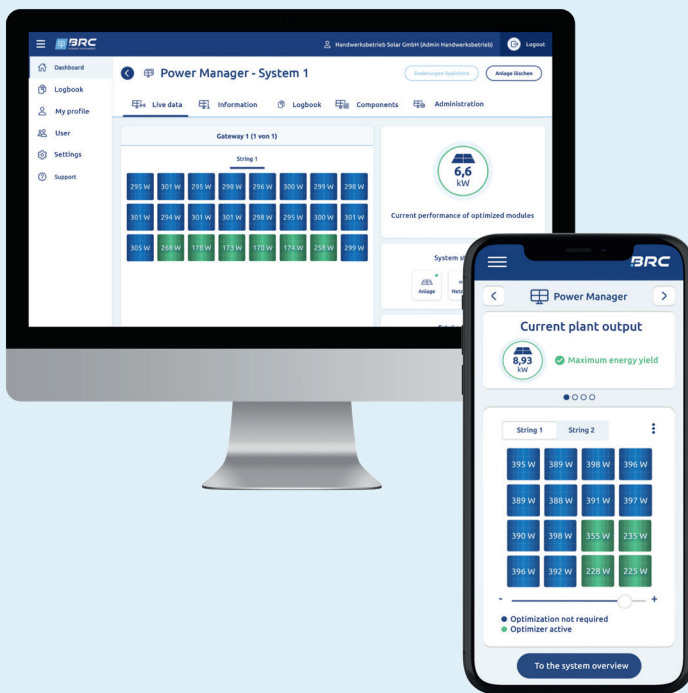

# It's that easy

## 1 Detect optimizers in the string

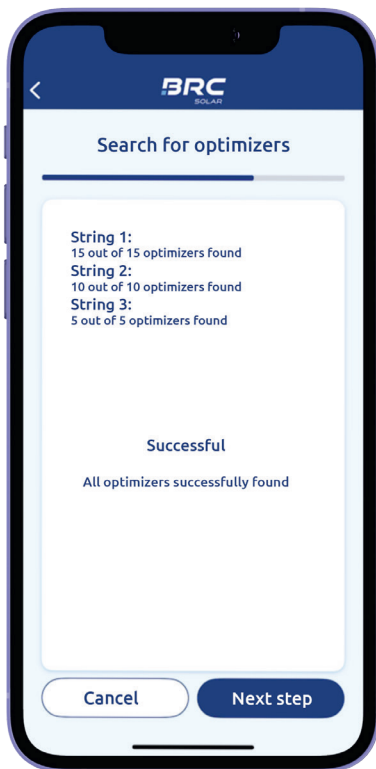

## 2 Recreate the system using drag & drop

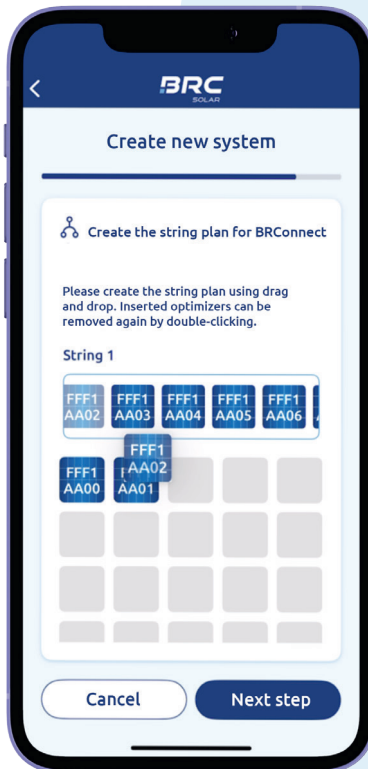

## 3 Complete digital PV system

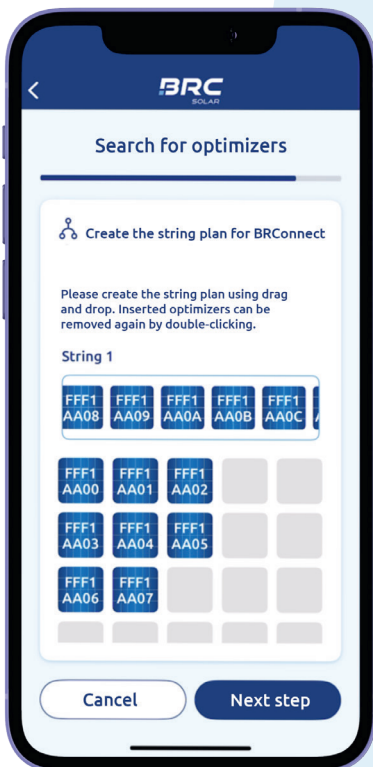

## 4 Monitor the optimized modules

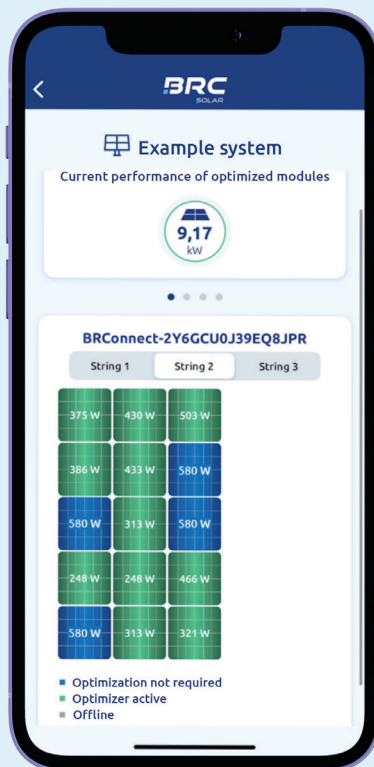

# BRC

SOLAR

GERMAN BRAND

## BRClamp

Module frame mounting



### **Mounting aid for all BRC optimizers**

Quick, secure mounting directly to the module frame – for a clean and efficient installation.



### **Maximum time savings**

The optimizers are pre-mounted to the module on the ground. All that remains to be done on the roof is to connect the string cables – perfectly prepared.



### **More flexibility**

Choose whether you want to mount the optimizer directly on the module frame using the BRClamp or attach it to the mounting frame.

New

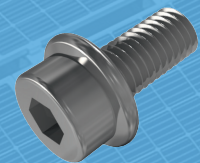
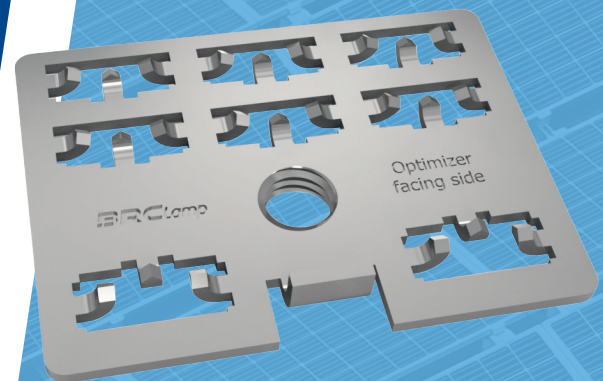

SIMPLE.  
SMART.  
OPTIMIZED.

# TECHNICAL DATA

DATA	
Dimensions (W x L x H)	40 mm x 53 mm x 1,5 mm
Weight	33 g
Mounting	with supplied M8 screw
Material	stainless steel
Scope of delivery	BRClamp and M8 screw
Screw head	6 mm (internal hex socket)
Packaging unit	150 pieces per box (15 bags containing 10 pieces each)



**!** Please ensure that the module is suitable for optimizer mounting with the BRClamp. Observe the length of the BRClamp screw so that the rear of the module is not damaged.

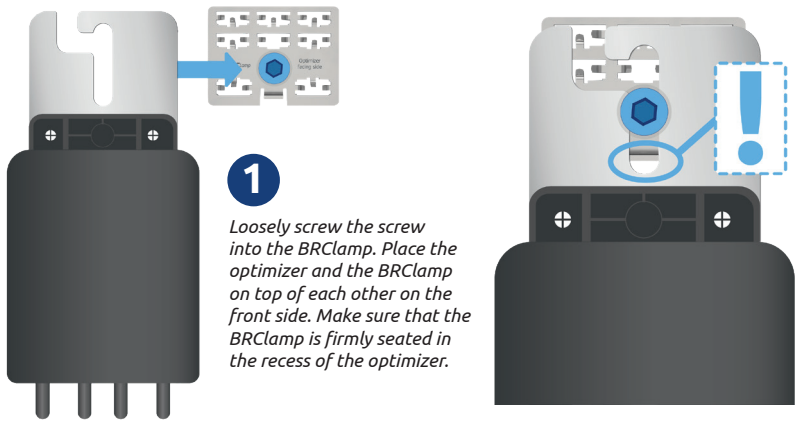

**1**  
Loosely screw the screw into the BRClamp. Place the optimizer and the BRClamp on top of each other on the front side. Make sure that the BRClamp is firmly seated in the recess of the optimizer.

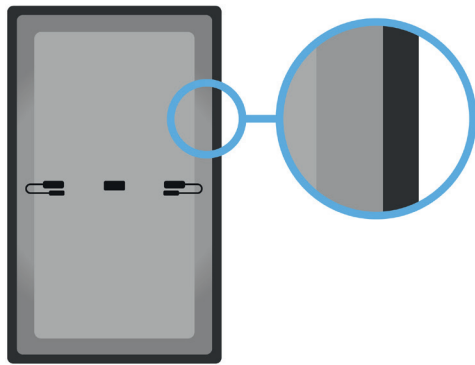

**2**  
Choose one side of the module frame on the back of your module for the placement of the optimizer.

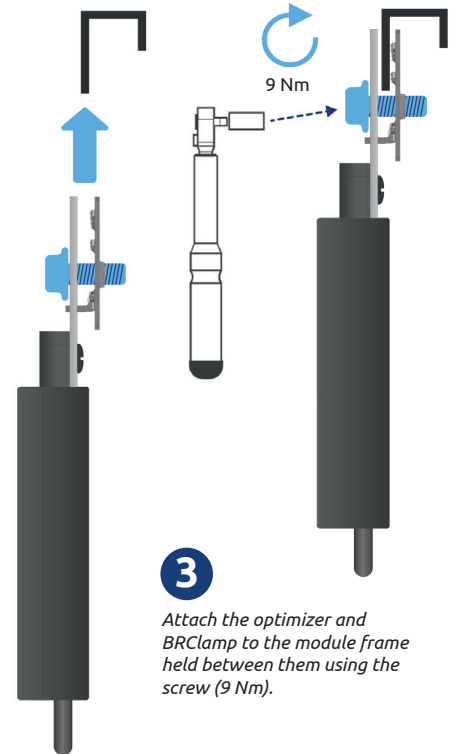

**3**  
Attach the optimizer and BRClamp to the module frame held between them using the screw (9 Nm).

Secure grip on the module frame



Easiest installation



# BRC-Advantages



German engineering / German **quality standards**



Professional **immediate assistance** from BRC support staff



Supporting **checker tools**



Always **full product warranty** (25 years for optimizers) without restrictions or conditions



Additional **replacement package** in the event of a warranty claim (If the installer is a member of the BRCademy)



Simple **installation videos** for support available at any time

## The BRCademy

*Discover the BRC training portal - your path to becoming a certified BRC-partner!  
Welcome to the future of training! With our in-house training portal, we offer you the opportunity to expand your expertise and benefit from exclusive advantages at the same time.*

- **Free registration:** Start your journey to becoming a certified BRC-partner without any costs. Sign up and get started today.
- **Interactive learning content:** Learn from the best! Our high-quality videos offer you practical insights and valuable tips that you can implement directly in your day-to-day work.
- **Certification:** Answer the questions on our learning content and secure the status of a certified BRC-partner. This certification will set you apart from the competition and show your customers that you are an expert in your field.
- **Exclusive benefits:** As a certified BRC-partner, you will receive a personal identification number that ensures you a additional replacement rate in the event of a warranty claim. Benefit from this unique opportunity and increase your added value!

*Become part of our BRCommunity!*

*Together we will shape the future - innovatively, competently and successfully!*

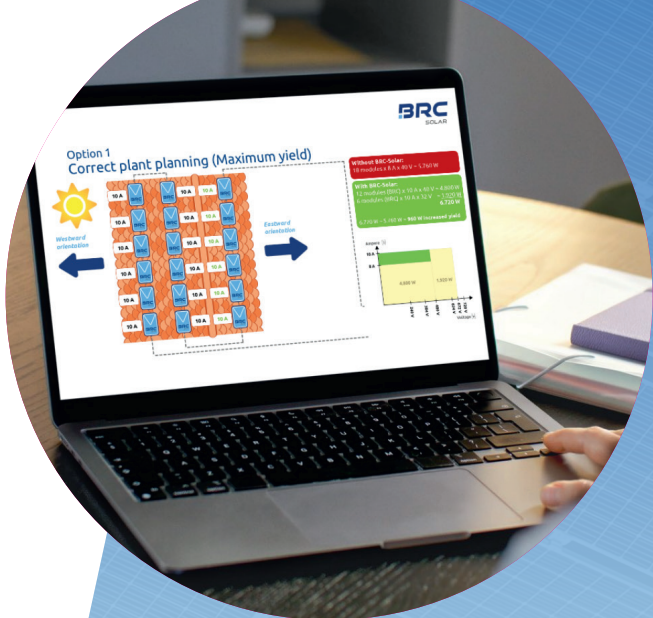

Sign up for free



Professional training videos



# BRC

## SOLAR

We support you with the following tools  
you with your planning:

✓ **Module checker**

✓ **Inverter checker**

✓ **Planning tool**

✓ **Order request**

*We will find the right  
wholesaler near you*



*To the  
planning aids*



*To the  
BRCademy*



*Free  
webinar*



*Newsletter  
registration*



**SIMPLE.  
SMART.  
OPTIMIZED.**